

VA E VIENI



MADE IN ITALY



La porta va e vieni e' formata da un battente spessore 40mm con finestrino 25x75
La porta puo' essere anche con 2 battenti.
Il telaio puo' essere in pvc con controtelaio, o a C di inox, o di alluminio regolabile per pannelli da 60 o 80mm.
Il telaio puo' essere anche in pvc con controtelaio.
l'interno del battente e' in polistirene incollato o in PUR.
L'esterno del battente e' in lamiera preverniciata o in inox.
Sula parte inferiore del battente internamente ed esternamente vengono fissati dei paracolpi che possono essere in alluminio, od inox incorporati nel battente o in pvc di forma convessa per assorbire i colpi dei carrelli (opzionale).
La guarnizione e' forma di pino a con 2 altezze differenti una a lato cerniere e l'altra a lato opposto.
Le cerniere sono a doppia molla con movimento all'interno del battente con apertura fissa a 90 gradi o con apertura libera.
Questa porta trova impiego in zone di intenso passaggio, come supermercati, cucine di ristoranti, aeroporti, etc,...

La porta puo' essere anche motorizzata.

TO AND FRO DOOR

*The to and fro door is a door with one wing or 2 wings, and the opening and closing is given by hinges with spring.
The hinge could be with free movement or fixed at 90° degree.
The inside of the blade can be in glued polystyrene or in PUR injected.
The outside of the frame is pre-painted galvanized steel or in stainless steel.
The frame can be C shape in inox or aluminium for panel of 60 and 80mm and in PVC with the counterframe. On the bottom of the frame are fixed bumper in stainless steel incorporated in the blade or in pvc rounded shape (optional).
The gasket is in epdm pine tree shape, with 2 sizes, one hinge side and the other at the opposite.
The hinges are with 2 spring and are fixed inside the blade.
This door finds its utilization in intensive passage areas, like supermarket, restaurant kitchen, airport and so on.*

PORTE VA ET VIEN

*Cette porte est destinée aux locaux de grand passage comme cuisines des restaurants, abattoirs, supermarchés, aéroports, la porte s'ouvre avec simple pression manuelle, grâce à ses charnières en pvc alimentaire avec double ressort, incorporé dans le vantail.
Les charnières sont avec blocage à 90° ou sans blocage.
Le vantail est de 40mm épaisseur isolé avec mousse PUR ou avec Polystyrène. Le parement du vantail est en tôle laquée ou inox, le bord du vantail est en alu ou inox.
La huisserie est en pvc avec contrecadre, ou à U de aluminium.
Les portes sont avec oculus cm 25x75 h.
Le vantail peut être avec protection de ailes d'avion en alu, inox ou en pvc (optionnel).*

PUERTA VA Y VIEN

*Esta puerta puede ser con oja sencilla o doble y con bisagras a doble resorte que permite a la puertas de abrirse y cerrarse con simple pression manual.
Por lo tanto es utilizada in lugar de alto trafico como clinicas, cocinas de restaurantes, salas de procesos alimenticios, supermercados.
Las bisagras son con movimiento fijo a 90° o con movimiento libre.
L'interior de la oja es in polistireno o in PUR inyectado.
L'acabado es en lamina galvanizada pintada, o in acero inoxidable, contorno en perfil de aluminio, empaque a 2 alturas, ajustadas al perfil perimetral de la oja que permite perfecto hermetismo. Visores ovalizados, cm 25x75 h. Parachoques optional.
El marco puede ser a U de aluminio, reglable de 60 a 80 mm de espesor del panel o in PVC con contromarco.*

PORTA VA E VIENI

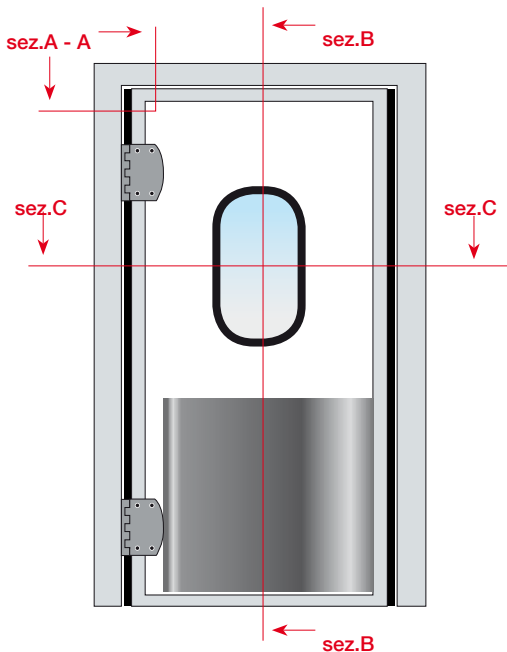
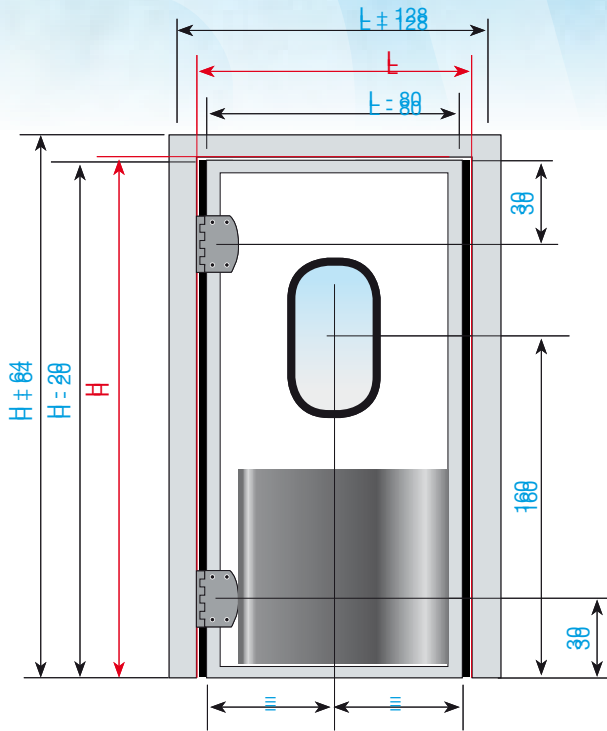

- Foro muro
- Size of the hole in the wall
- Cotes de reservation
- Medida del fuero en el panel

SEZ B - B

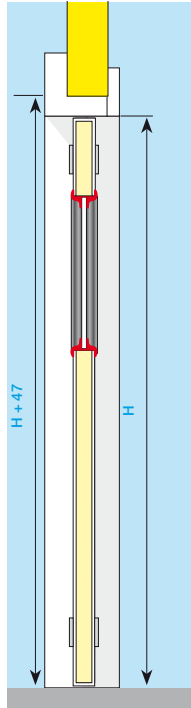

TELAIO E CONTROTELAIO IN PVC

FRAME AND COUNTERFRAME
PVC CADRE ET CONTRECADRE
PVC MARCO Y CONTRAMARCO

SEZ A - A

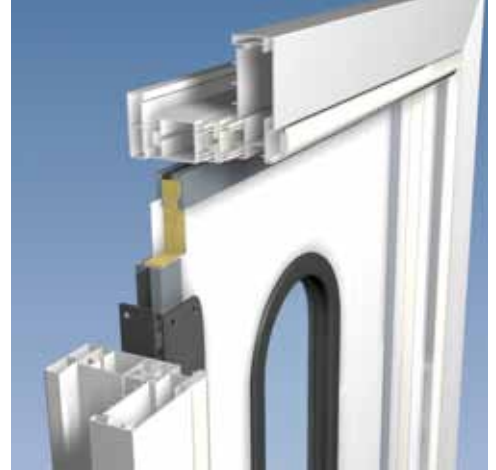

SEZ C - C

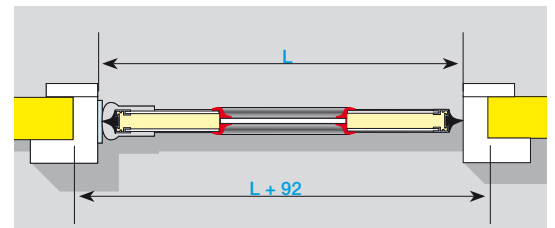

PROFILO A "C" PER TELAIO SPESSORE 60 MM

FRAME "C" PROFILE IN ALUMINIUM THICKNESS 60MM
HUISSERIE A "C" IN ALUMINIUM 60MM EPAISSEUR
MARCO A "C" DE ALUMINIO 60MM LARGO

- Foro muro
- Size of the hole in the wall
- Cotes de reservation
- Medida del fuero en el panel

SEZ B - B

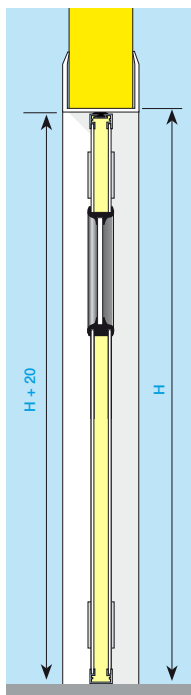

SEZ A - A



SEZ C - C

